

PART NO.	DIM "A"	DESCRIPTION
10068597-1****	12.00	1.5V
10068597-2****	11.00	X.XV
10068597-3****	13.00	X.XV

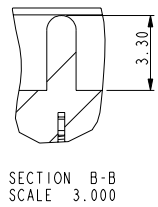
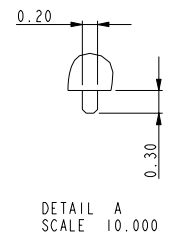
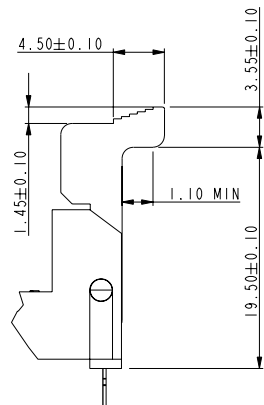
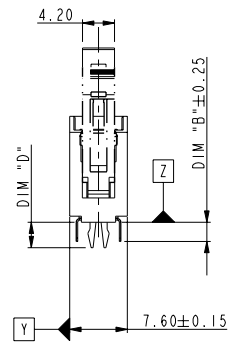
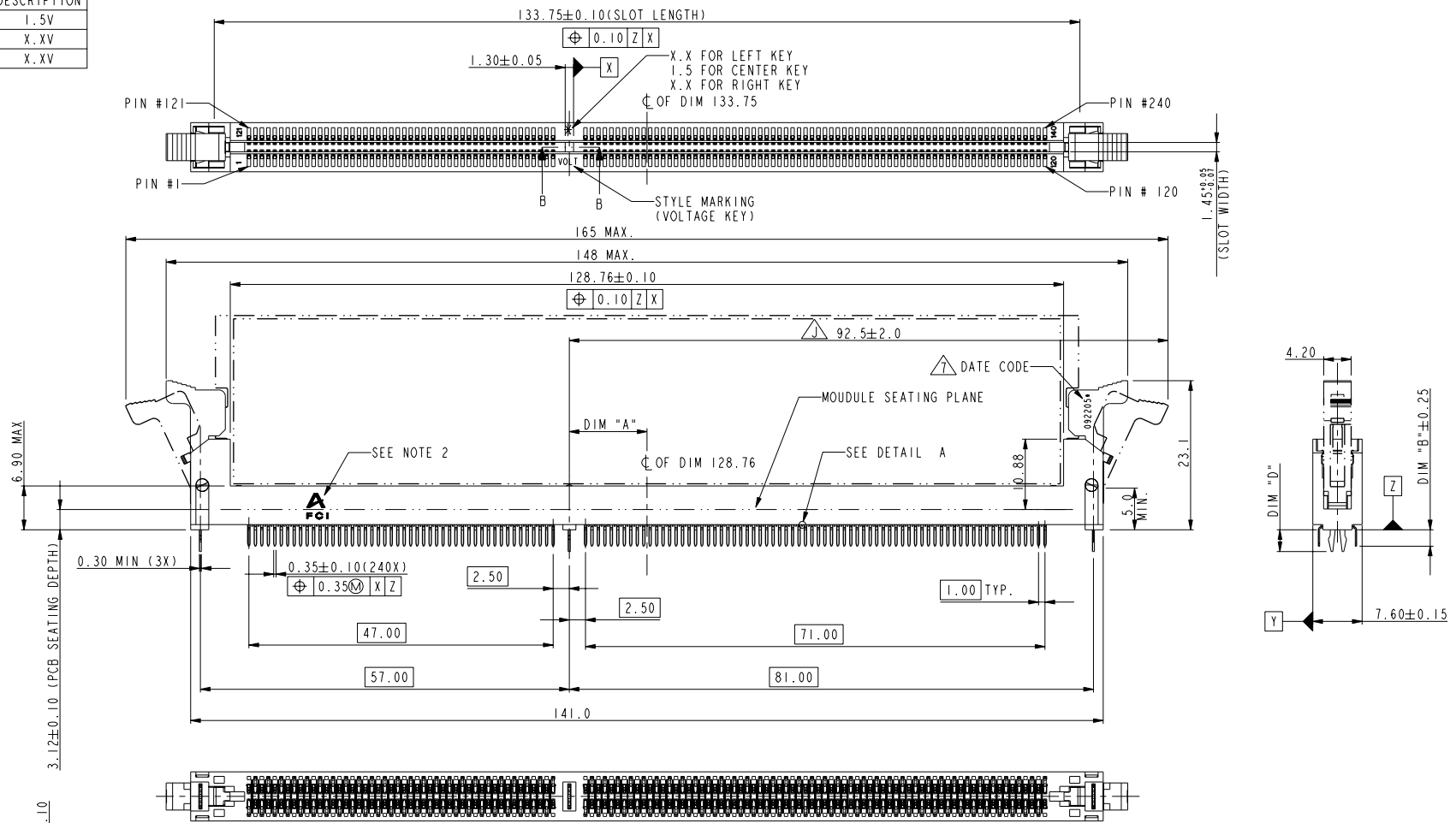

Copyright FCI.

rev	ecn no	dr	date
H	DG08-0359	B L	12/25/08
J	DG09-0174	B L	06/01/08
K	DG09-0369	B L	11/25/09
L	N10-0025	R.B	04/16/2010
F	DG08-0065	J W	03/19/08
G	DG08-0172	B L	07/23/08

www.fciconnect.com		surface	tolerance std	projection	MM
		ANGULAR	LINEAR	size	Scale
Dr	CHARLIE S	04/06/06	0.X ± .38	A4	0.500
Eng	CAHRLIE S	04/06/06	0.XX ± .25	ECN	N10-0025
Chr	BEER FU	04/06/06	0.XXX ± .13	Product family	Spec ref
Appr	JOSEPH HSIA	04/06/06			*
FCI		title		dwg no	
		DDR111 240P V/T METAL CLIP ASS'Y		10068597	
		catalog no		CUSTOMER	
				sheet 1 of 4	

REV F - 2006-04-17



Copyright FCI.

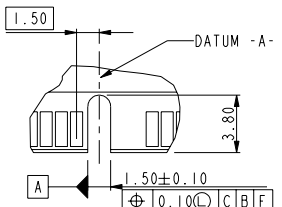
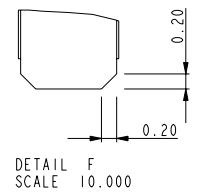
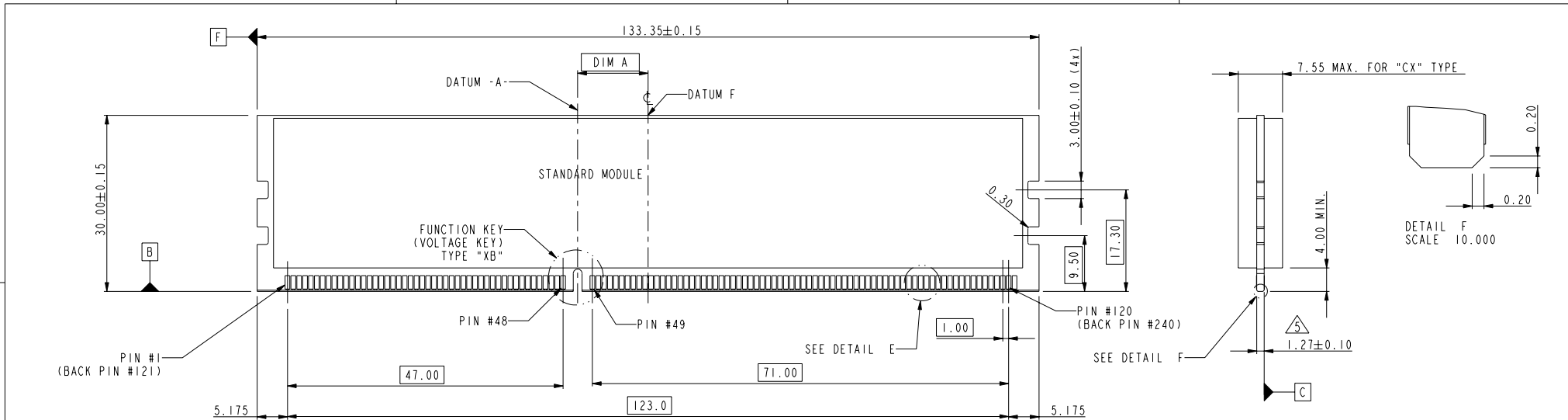

FUNCTION KEY
KEY POSITION LEFT
TYPE "XA"
SCALE 2.000

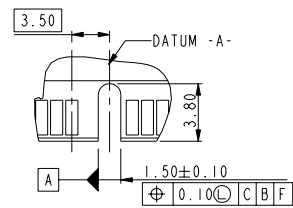

FUNCTION KEY
KEY POSITION RIGHT
TYPE "XC"
SCALE 2.000

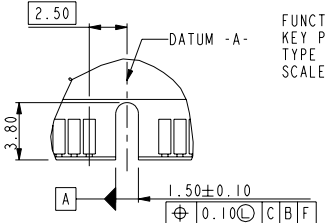

FUNCTION KEY
KEY POSITION CENTER
TYPE "XB"
SCALE 2.000

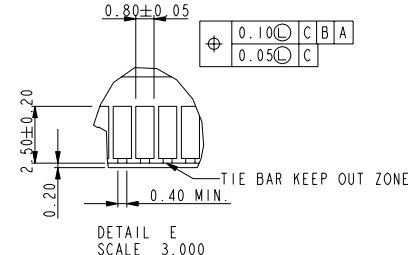

TYPE "XA"	X.X VOLTAGE
TYPE "XC"	X.X VOLTAGE
TYPE "XB"	1.5 VOLTAGE
SUB KEY POS #1	DESCRIPTION

tolerance unless otherwise specified	
linear	.X ± .38
	.XX ± .25
	.XXX ± .13
angles	0° ± 2°

FCI		title	DDRIII 240P V/T METAL CLIP ASS'Y	dwg no	10068597	Rev.	L
FCI		catalog no	-	CUSTOMER	sheet 2 of 4		

REV F - 2006-04-17



Copyright FCI.

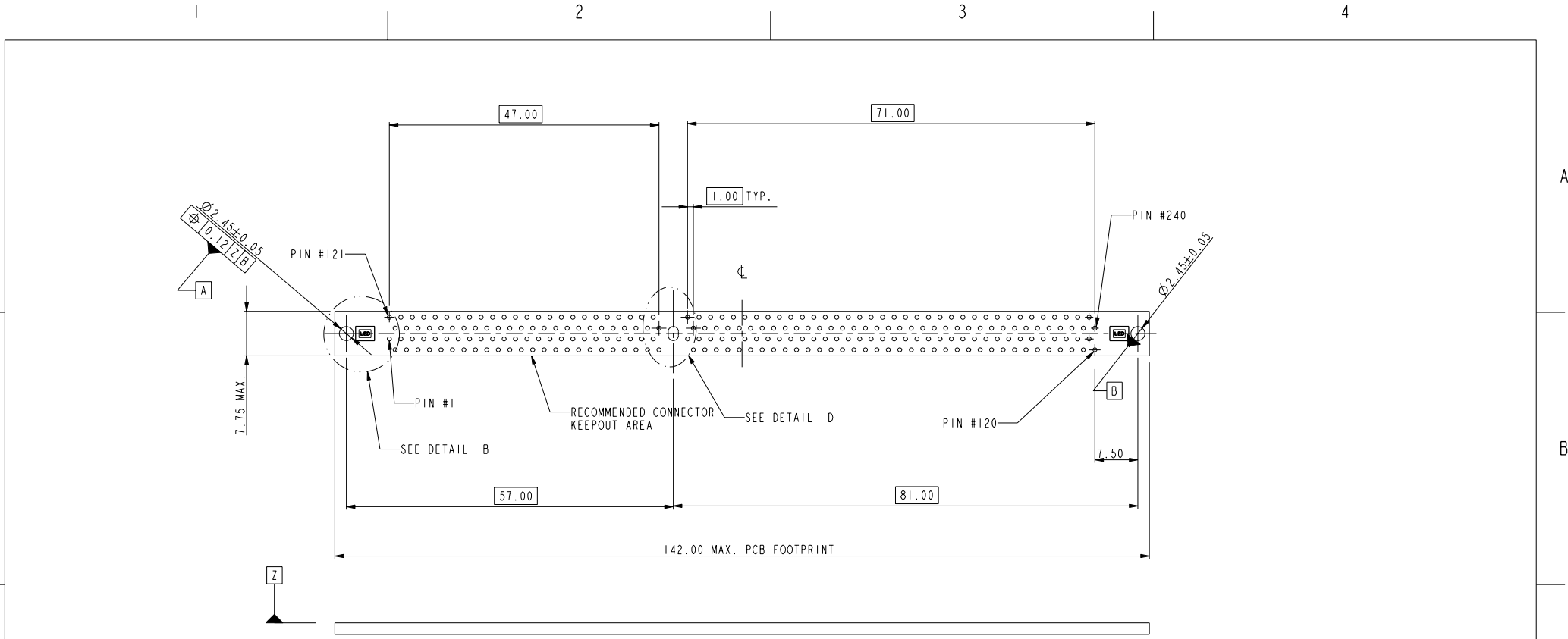

RECOMMENDED CIRCUIT BOARD HOLE LAYOUT

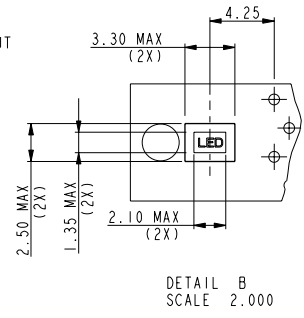
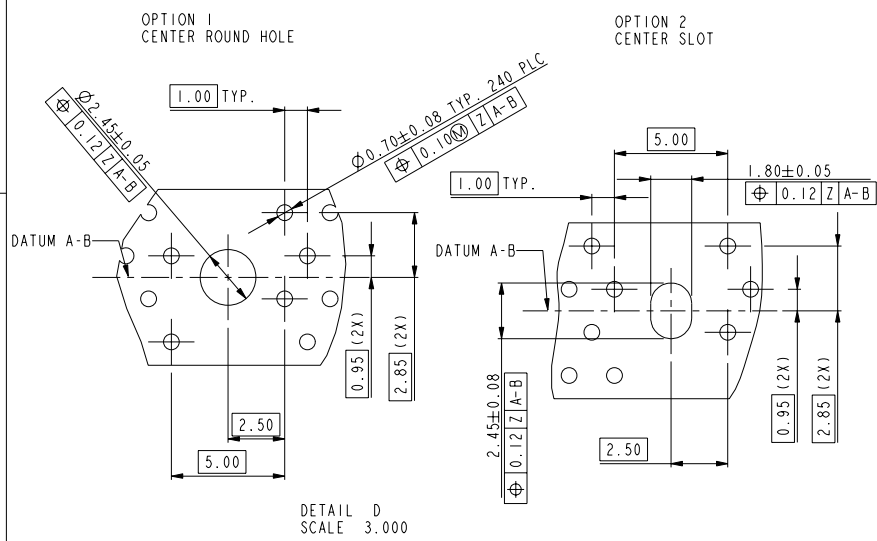

tolerance unless otherwise specified	
linear	.X ± .38
	.XX ± .25
	.XXX ± .13
angles	0° ± 2°

	title	DDRIII 240P V/T METAL CLIP ASS'Y	dwg no	10068597	Rev.	L
	catalog no	-	CUSTOMER	sheet 3 of 4		

REV F - 2006-04-11

10068597 - □ □ □ □

STYLE : MECHANICAL KEYING

- 1 : 1.5 VOLT. W/ CENTER KEY "XB"
- 2 : X.X VOLT. W/ LEFT KEY "XA"
- 3 : X.X VOLT. W/ RIGHT KEY "XC"

CODE	METAL CLIP	TAIL LENGTH
	DIM "D"	DIM "B"
11	3.05	2.67
22	3.56	3.18

PLATING

CODE	CONTACT	SOLDERTAIL	UNDERPLATE
2	15u" (0.38um) MIN. GOLD		
3	30u" (0.76um) MIN. GOLD	100u" (2.54um) MIN. TIN/LEAD	50u" (1.27um) MIN. NICKEL OVERALL
4	3u" (0.07um) MIN. GOLD		
5LF	20u" (0.508um) MIN. GOLD		90u" (2.29um)MIN. NICKEL OVERALL
7LF	15u" (0.38um) MIN. GOLD	100u" (2.54um) MIN. 100% TIN	
8LF	30u" (0.76um) MIN. GOLD		50u" (1.27um) MIN. NICKEL OVERALL
9LF	3u" (0.07um) MIN. GOLD		

COLOR OF HOUSING AND EJECTOR

- 0 : BLACK HOUSING + IVORY EJECTOR
- 1 : BLUE HOUSING + IVORY EJECTOR
- 2 : BLACK HOUSING + BLACK EJECTOR
- 3 : BLACK HOUSING + CLEAR EJECTOR
- 4 : BLUE HOUSING + CLEAR EJECTOR
- 5 : IVORY HOUSING + CLEAR EJECTOR
- 6 : BLACK HOUSING + BLUE (2945C) EJECTOR
- 7 : IVORY HOUSING + IVORY EJECTOR
- 8 : BLACK HOUSING + GREEN (375C) EJECTOR
- 9 : IVORY HOUSING + BLACK EJECTOR
- △ C : BLUE HOUSING + BLACK EJECTOR

NOTES:

1. MATERIAL:
HOUSING: HIGH PERFORMANCE RESINS, GLASS FILLED UL94V-0 RATED.
EJECTOR: HIGH PERFORMANCE RESINS, GLASS FILLED UL94V-0 RATED.
TERMINAL: COPPER ALLOY.
METAL CLIP: COPPER ALLOY.
2. FCI LOGO TO BE APPROXIMATELY LOCATED AS SHOWN ON PRINT.
3. PRODUCT SPECIFICATION: GS-12-368.
4. PACKAGING SPECIFICATION: GS-14-899.
- △ 5. CARD THICKNESS APPLIES ACROSS TABS AND INCLUDES PLATING AND/OR METALIZATION.
- △ 6. LEADING EDGE OF CONTACT PADS SPECIFIED BY THE KEEP OUT ZONE SHALL BE FREE OF BURRS AND EXTERNAL TIE BARS. FOR OPTIMUM PERFORMANCE. THE TIE BAR IS TO BE ON AN INTERNAL LAYER SO THAT THE REMNANT CANNOT CAUSE CONTACT DAMAGE.
- △ 7. THE DATE CODE IS SHOWN "MMDDYY*"."*" MEANS PRODUCTION LINE CODE.
8. SOCKET IS COMPLIANT TO JEDEC SO-007 AND ACCEPTS JEDEC MODULE MO-269, VARIATIONS AA THRU FC.
9. THIS PRODUCT MEETS EUROPEAN UNION DIRECTIVES AND OTHER COUNTRY REGULATIONS AS DESCRIBED IN GS-22-008.
10. THE HOUSING WILL WITH STAND EXPOSURE TO 260°C PEAK TEMPERATURE FOR 10 SECONDS IN A WAVE SOLDER APPLICATION.
11. THE CLEAR LATCH CAN WITHSTAND MAX 174°C EXPOSURE TEMPERATURE.

tolerance unless otherwise specified	
linear	.X ± .38
	.XX ± .25
	.XXX ± .13
angles	0° ± 2°

	title	DDRIII 240P V/T METAL CLIP ASS'Y	dwg no	10068597	Rev. L
	catalog no	-			



Copyright FCI.